

Product Data Sheet

SF130-L

SF140-L

SF145-L

SF150-L



Next Generation CIS

Solar Frontier's new SF130–150 module series offers the highest conversion efficiency of any mass-produced thin-film module, up to 12.2%. The modules feature the light-soaking effect unique to Solar Frontier's CIS technology, which provides higher output than initially specified. All modules are RoHS compliant and cadmium- and lead-free. Fewer production steps and raw materials also mean an industry-leading energy payback time of less than one year. SF130–150 modules are shipped in cardboard-free packaging and use recyclable corner pieces.

Product & Technology Highlights

- Highest efficiency mass-production thin-film module, up to 12.2%
- World record 16.3% achieved in laboratory (30 cm x 30 cm module)
- Up to 10% extra kWh/kWp vs crystalline modules
- Light soaking effect boosts output after installation
- 77 MW delivered worldwide since 2007
- Based on proprietary R&D since 1978
- Cadmium and lead free
- Energy Payback Time under one year

I-V Curve

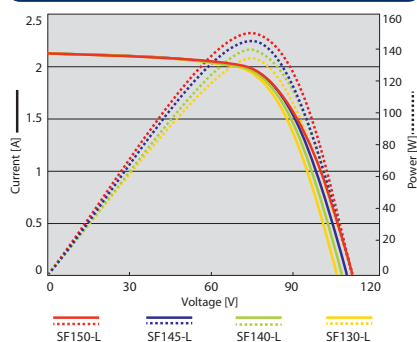

Certificates and Compliance*



* IEC and TUV certifications for SF145 and SF150 modules are pending. UL certification for all modules is pending.

Module Drawing

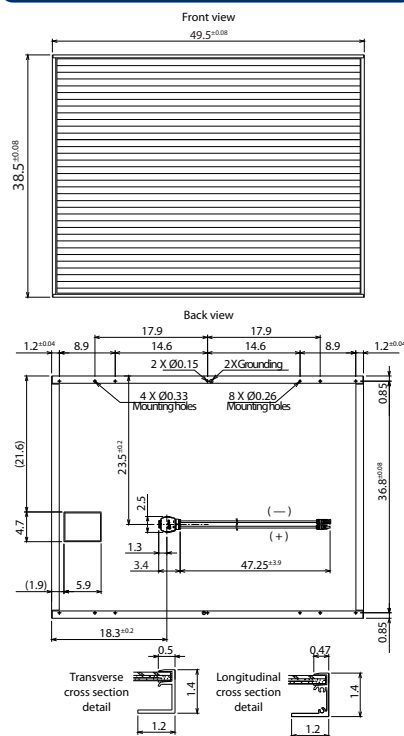

Contact Information

Solar Frontier K.K.
 (HQ, Asian Sales Office)
 Tokyo, Japan
 Tel: +81-3-5531-5626

Solar Frontier Americas
 Santa Clara, CA, USA
 Tel: +1-408-850-7218

Solar Frontier Europe
 Munich, Germany
 Tel: +49-89-92-86-142-22

www.solar-frontier.com/contact

STC Characteristics

		SF130-L	SF140-L	SF145-L	SF150-L
Maximum power	P _{max}	130 W	140 W	145 W	150 W
Tolerance of P _{max}		+10%/-5%			
Factory binning		-2.5 W/+7.5 W	±2.5 W	±2.5 W	±2.5 W
Open circuit voltage	V _{oc}	106.0 V	109.0 V	110.0 V	110.0 V
Short circuit current	I _{sc}	2.10 A	2.10 A	2.10 A	2.10 A
Voltage at maximum power	V _{mpp}	74.0 V	77.0 V	78.0 V	79.0 V
Current at maximum power	I _{mp}	1.77 A	1.82 A	1.86 A	1.90 A

Standard Test Conditions (STC): 1,000 W/m² irradiance, module temperature 25 °C (77 °F), air mass 1.5. I_{sc} and V_{oc} are ±10% tolerance of STC rated values. Module output may rise after light soaking due to its unique characteristics.

NOCT Characteristics

		SF130-L	SF140-L	SF145-L	SF150-L
Maximum power	P _{max}	94.7 W	102 W	106 W	109 W
Open circuit voltage	V _{oc}	95.1 V	97.8 V	98.7 V	98.7 V
Short circuit current	I _{sc}	1.66 A	1.66 A	1.66 A	1.66 A
Voltage at maximum power	V _{mpp}	69.8 V	72.7 V	73.6 V	74.5 W
Current at maximum power	I _{mp}	1.37 A	1.41 A	1.44 A	1.47 A

Nominal Operating Cell Temperature Conditions: Module operating temperature at 800 W/m² irradiance, air temperature 20 °C (68 °F), wind speed 1 m/s and open circuit condition.

Performance at Low Irradiance

Efficiency reduction of maximum power from an irradiance of 1,000 W/m² to 200 W/m² at 25 °C (77 °F) is typically 3.0%. The standard deviation for the reduction of efficiency is 2.6%.

Temperature Characteristics

NOCT		47 °C (116 °F)
Temperature coefficient of I _{sc}	α	+0.01%/K
Temperature coefficient of V _{oc}	β	-0.30%/K
Temperature coefficient of P _{max}	δ	-0.31%/K

Mechanical Characteristics

Dimensions (L x W x H)	1,257 x 977 x 35 mm (49.5 x 38.5 x 1.4 in.)
Weight	20 kg (44.1 lbs)
Application class (IEC 61730)	A
Fire rating (IEC 61730)	Class C
Safety class (IEC 61140)	II
Snow/wind load*	2,400 Pa (IEC 61646) / 1,600 Pa design load (UL 1703)
Cell type	CIS glass substrate (cadmium free)
Front cover	Clear tempered glass, 3.2 mm
Encapsulant	EVA
Back sheet	Weatherproof plastic film (color: black & silver)
Frame	Anodized aluminum alloy (color: black)
Edge sealant	Butyl rubber
Junction box	Protection rating: IP 67 (with bypass diode)
Adhesive	Silicone
Output cables (conductor)	2.5 mm ² / 14 AWG (halogen free)
Cable lengths (symmetrical)	1,200 mm (47.2 in.)
Connectors	MC 4 compatible
Packing information	25 panels/pallet • 36 pallets/40' container (900 panels)

* UL: 1.5 x design load is applied to the module, i.e. 2,400 Pa (50.1 lbs/ft²) is applied to meet the 1,600 Pa UL design load standard.

This preliminary data sheet is provided to assist you in evaluating this product that is under development. Solar Frontier K.K. reserves the right, at its sole discretion, to change, modify, add or delete portions of the content at any time without notice.